

REV.	ECN NO.	LOCATIONS	DESCRIPTION	DATE	DESIGN
C			新增Au15規格與Au30u"規格料號	02/10'07	肖彪

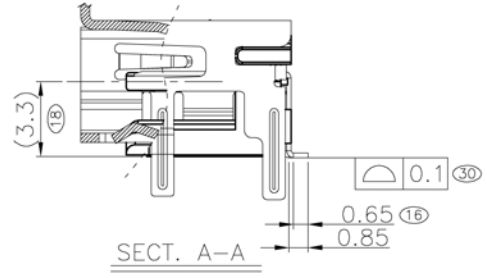

NOTE:

- MATERIAL:
 - HOUSING:THERMOPLASTIC,HIGH TEMP, UL94V-0 COLOR:BLACK
 - CONTACT:COPPER ALLOY.
 - SHELL:COPPER ALLOY.
- FINISH
 - CONTACT: GOLD PLATING SEE TABLE AT CONTACT AREA MATTE TIN PLATING AT SOLDER AREA. NICKEL UNDERPLATED ALL OVER.
 - SHELL:SOLDER NICKEL PLATED ON ALL OVER
- APPLIED TO IR SOLDERING PROCESS
- REFLOW SOLDER CAPABLE TO 260°C MAX. 10sec.
- MEET TO ROHS OF SONY-SS00259 AND PANASONIC GP.
- DATE CODE.
- MARKED (X) DIMENSIONS NEED BE MEASURED IN FAI.

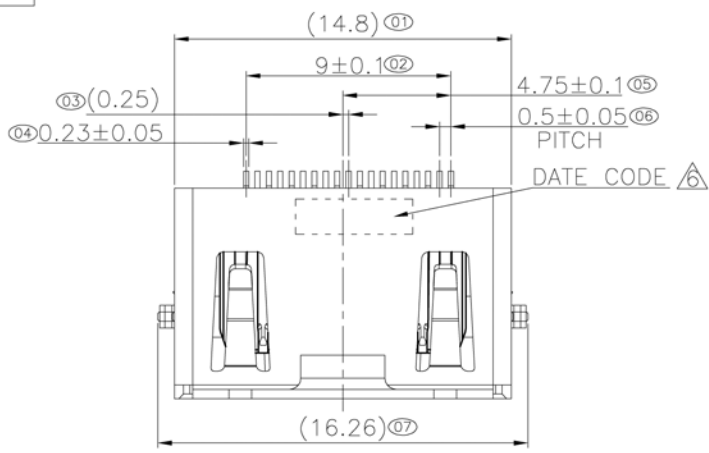
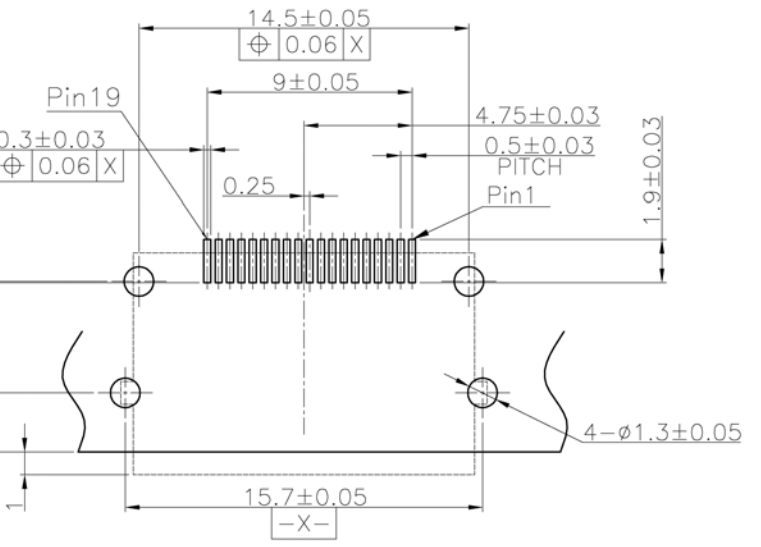
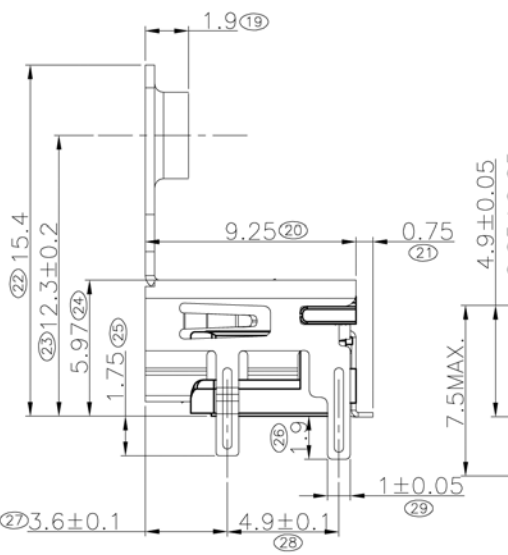
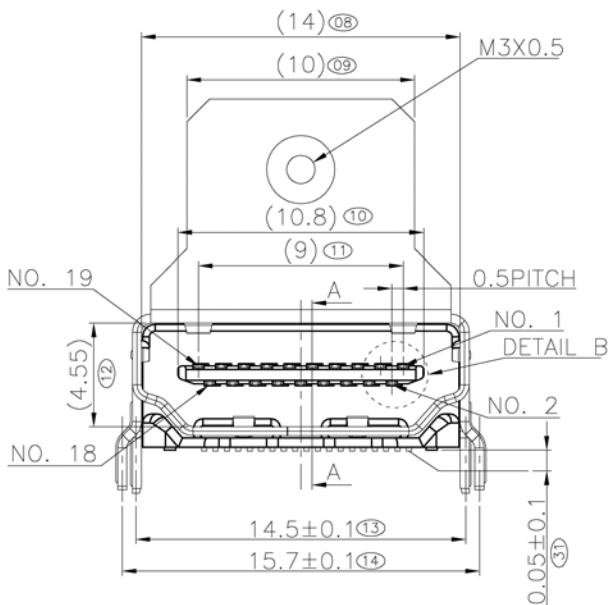

APPLICABLE P.C.B. DIMENSION (THICKNESS=1.6MM REF)

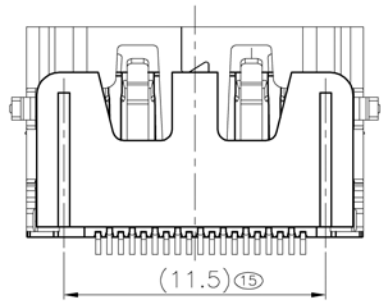

- Part Numbers
- CCHDMI-0051-1931 - Au 5u" - Tray
 - CCHDMI-0053-1931 - Au 5u" - Reel
 - CCHDMI-0054-1931 - Au 30u" - Tray
 - CCHDMI-0055-1931 - Au 30u" - Reel
 - CCHDMI-0058-1931 - Au 15u" - Tray
 - CCHDMI-0059-1931 - Au 15u" - Reel

DIM	TOL	DIM	DEG	CYPRESS INDUSTRIES www.cypressindustries.com			
X	±0.35	X'	±5°	FILE: _____		DRAW NAME: _____	
X.X	±0.25	X.X'	±3°	DRAW NO. _____		HDMI SMT TYPE FLANGE TRAY	
X.XX	±0.20	X.XX'	±2°	P/N: SEE TABLE		MODEL: _____	
X.XXX	±0.10	X.XXX'	±1°	UNIT: mm	SCALE: N/A	HDMI SMT CONNECTOR	
DESIGN:	肖彪	01/10'07		REV: C	SHEET: 1/3		
CHECK:	李清亮	01/10'07					
APPROVED	鄭家茂	01/10'07					

REV.	ECN NO.	LOCATIONS	DESCRIPTION	DATE	DESIGN
C			新增Au15規格與Au30u"規格料號	02/10'07	肖彪

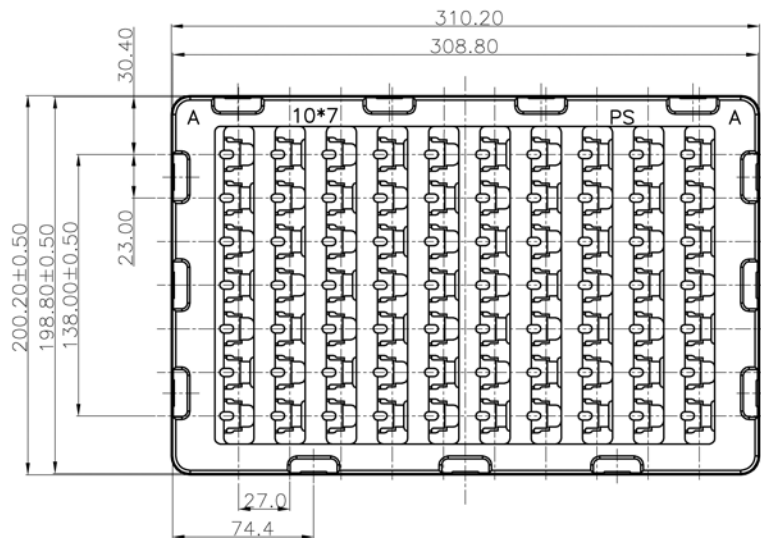

TRAY A LAYOUT
SCALE: 1:10

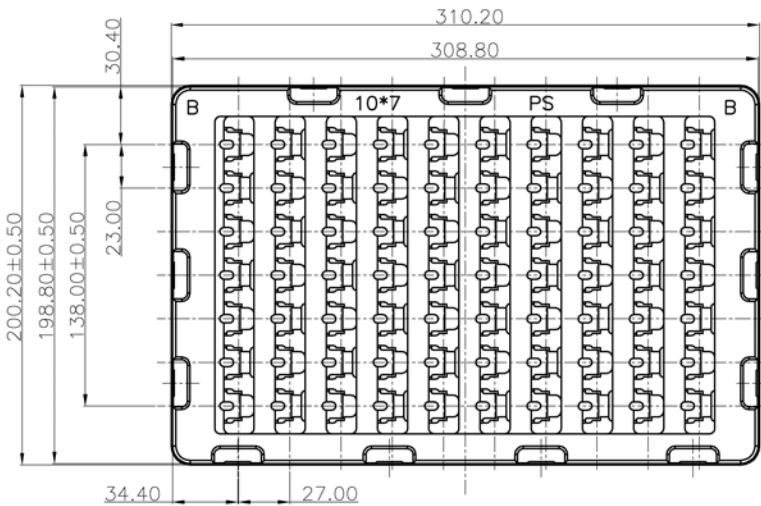

TRAY B LAYOUT
SCALE: 1:10

NOTES :

1. MATERIAL :
 - 1.1 TRAY : PS
2. DIMENSION :
 - 2.1 TRAY : L=310.2, W=200.2, H=20.7
 - 2.1 SHIPPING CARTON : L=325, W=210, H=390
3. QUANTITY :
 - 3.1 PRIMARY PACKING: 70 PCS/TRAY
 - 3.2 SECONDARY PACKING: 20 TRAY/CARTON(1400PCS)

CARTON BOARD

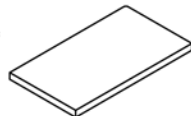

TRAY A

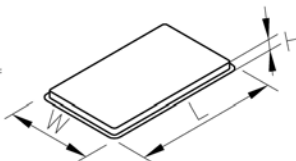

TRAY B

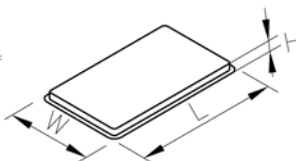

CARTON BOARD

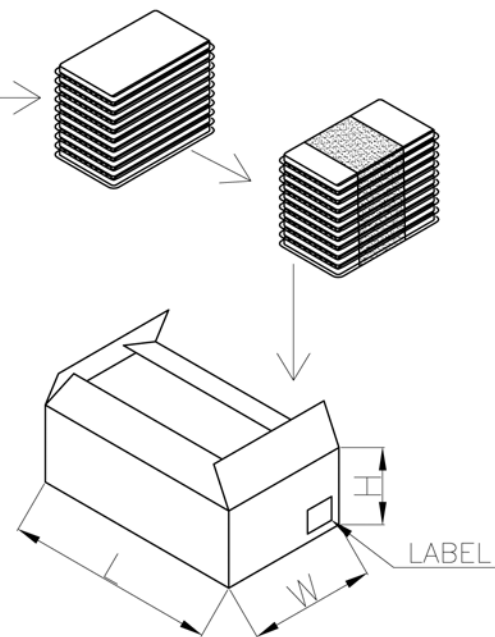
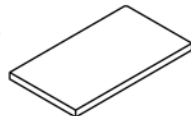

DIM	TOL	DIM	DEG
X	±0.35	X°	±5°
X.X	±0.25	X.X°	±3°
X.XX	±0.20	X.XX°	±2°
X.XXX	±0.10	X.XXX°	±1°

CYPRESS INDUSTRIES
www.cypressindustries.com

FILE: _____	DRAW NAME: _____
DESIGN: 肖彪 02/10'07	DRAW NO. _____
CHECK: 李清亮 02/10'07	P/N: SEE TABLE
APPROVED: 鄭家茂 02/10'07	UNIT: mm SCALE: N/A
	REV: C SHEET: 2/3
	MODEL: HDMI SMT TYPE FLANGE TRAY CUSTOMER DRAWING
	MODEL: HDMI SMT CONNECTOR

REV.	ECN NO.	LOCATIONS	DESCRIPTION	DATE	DESIGN
C			新增Au15規格與Au30u"規格料號	02/10'07	肖 彪

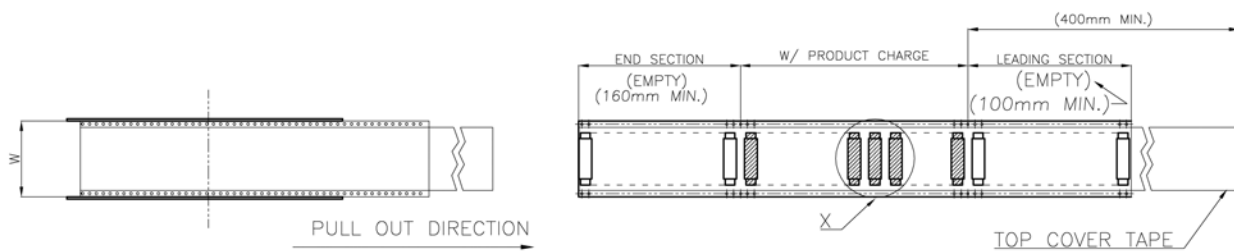

- NOTES:
- MATERIAL :
 - EMBOSSED CARRIER: PS
 - COVER TAPE: PS
 - SHIPPING CARTON: CORRUGATED FIBER
 - DIMENSION :
 - REEL: W=44
 - SHIPPING CARTON: L=335, W=335, H=248
 - QUANTITY :
 - PRIMARY PACKING: 130PCS/REEL
 - SECONDARY PACKING: 4 REELS/CARTON(520PCS)
 - PEELING RESISTANCE: 10.2gf~71.4gf.
 - PEELING SPEED: 300mm/minutes.

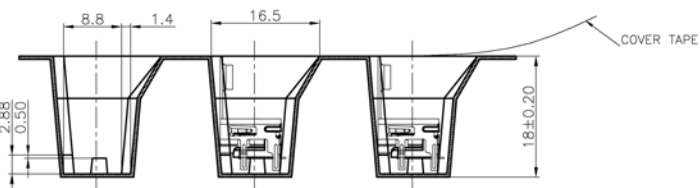
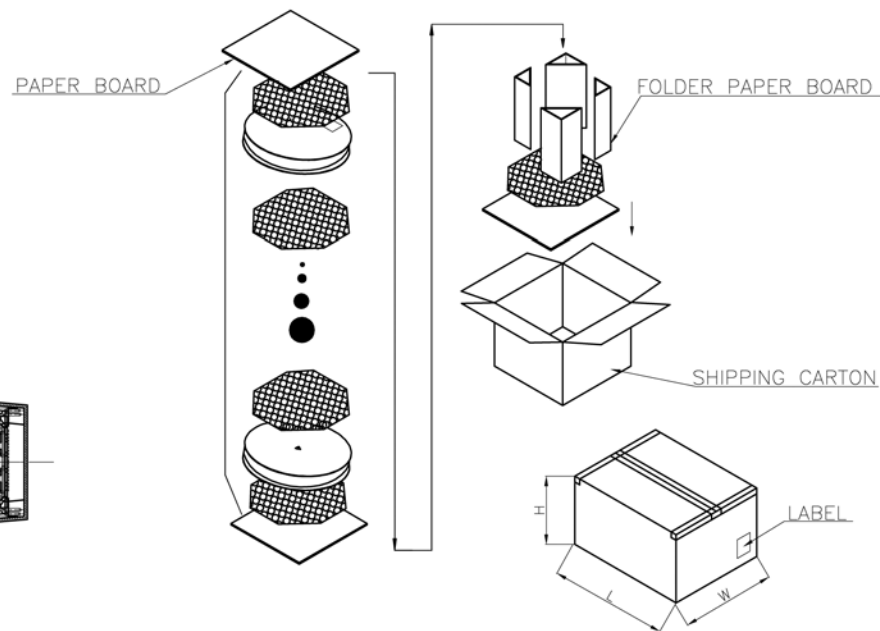
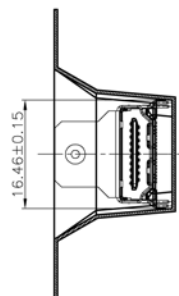
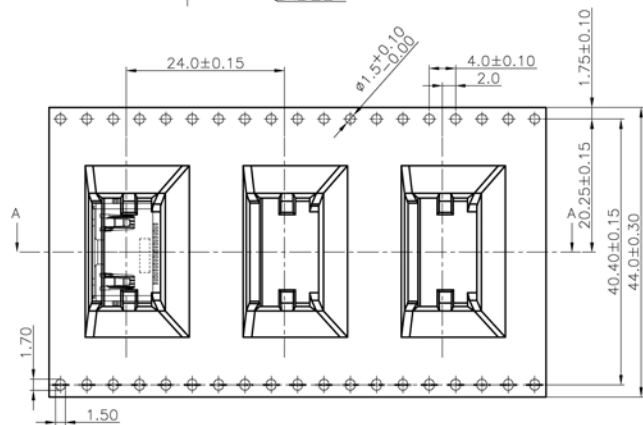
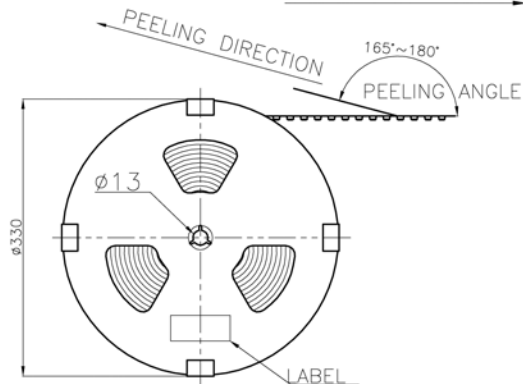

DIM TOL DIM DEG X ±0.35 X' ±5° X.X ±0.25 X.X' ±3° X.XX ±0.20 X.XX' ±2° X.XXX ±0.10 X.XXX' ±1°				CYPRESS INDUSTRIES www.cypressindustries.com	
DESIGN:	肖 彪	02/10'07	FILE:	DRAW NAME:	
CHECK:	李清亮	02/10'07	P/N:	SEE TABLE	
APPROVED:	鄭家茂	02/10'07	UNIT: mm	SCALE: N/A	MODEL:
			REV: C	SHEET: 3/3	HDMI SMT CONNECTOR